

JT AUTOMATION TECHNOLOGY LTD

ENVIRONMENTAL

POLICY & PROCEDURES MANUAL

JULY 2009



Last Reviewed: 18th July 2009
Next Scheduled Review: 17th July 2010

JT AUTOMATION TECHNOLOGY LTD

ENVIRONMENTAL POLICY & PROCEDURES MANUAL

RECORD OF AMENDMENTS

Date	Issue	Amended By	Comments/Details
18 th July 2009	A	Safety Services Direct Ltd	First Issue

CONTENTS

Section One – Policy and Organisation

- 1.0 Environmental Policy Statement
- 2.0 Organisation
- 3.0 Implementation of the Policy
- 4.0 Environmental Management Responsibilities
 - 4.1 Managing Director
 - 4.2 Company Directors
 - 4.3 Environmental Manager
 - 4.4 Senior Management
 - 4.5 All Employees

Section Two – Environmental Management Procedures

- Air Pollution
- Contaminated Land
- Ecology, Archaeology and Cultural Heritage
- Noise and Vibration
- Sustainable Development
- Statutory Nuisance
- Traffic Management
- Water Pollution
- Delivery, Storage, Refuelling and Spills of Fuel and Chemicals
- Environmental Impact/Risk Assessments
- Environmental Performance, Monitoring and Review
- Environmental Management Information
- Site Waste Management Plans

Section Three – Miscellaneous Forms

- Environmental Audit Checklist
- Environmental Risk Assessment Form
- Environmental Incident Report Form
- Waste Transfer Note
- Employee Environmental Training Record
- Environmental Legislation
- Simple Site Waste Management Plan Template

Glossary of Key Environmental Terms

Section One

Policy & Organisation

1.0 STATEMENT OF POLICY

JT AUTOMATION TECHNOLOGY LTD

ENVIRONMENTAL POLICY STATEMENT

JT Automation Technology Ltd is a professional and environmentally conscious organisation, which acknowledges the impact that our operations may potentially have on the environment. The clear objective of JT Automation Technology Ltd is to minimise any impact on the environment by:

- Preventing pollution, reducing waste and ensuring wherever practical measures are implemented to protect and preserve natural habitats, flora and fauna;
- Considering the effects that our operations may have on the local community;
- Taking action to eliminate or reduce as far as practicable, any potentially adverse environmental impacts;
- Promote environmental awareness amongst our suppliers, contractors and partners by implementation of operational procedures;
- Seek to work in partnership with the community by behaving in a considerate and socially responsible manner;
- Ensure effective and expedient incident control, investigation and reporting

Management and supervisory staff have responsibilities for the implementation of the policy and must ensure that environmental issues are given adequate consideration in the planning and day-to-day supervision of all work.

JT Automation Technology Ltd will fully comply with the duties placed upon it within the requirements of Statutory Legislation, whilst at all times complying with, as a matter of best practice, the requirements and duties set out within Approved Guidance as issued by the Environment Agency and other organisations.

All employees and sub-contractors are expected to co-operate and assist in the implementation of this policy, whilst ensuring that their own works, so far as is reasonably practicable, are carried out without risk to themselves, others or the environment. This includes co-operating with management on any environment related matter.

JT Automation Technology Ltd will take all practical steps to ensure that potential hazards and risks to the environment are identified and that suitable and effective preventative and control measures are implemented. All employees will be provided with the necessary resources, equipment, information, instruction and training to fulfill the requirements of this policy.

The Directors have overall responsibility for all Environmental matters. The operation of this policy and the associated procedures will be monitored and reviewed on a regular basis to ensure that they remain current and applicable to the company's activities. This policy has been endorsed by the Board of Directors who gives their full support to the implementation of the policy.

Signed:

Date: 18 July 2009

Director

2.0 ORGANISATION

The following organisation chart outlines the structure for the management of Environmental issues within JT Automation Technology Ltd.

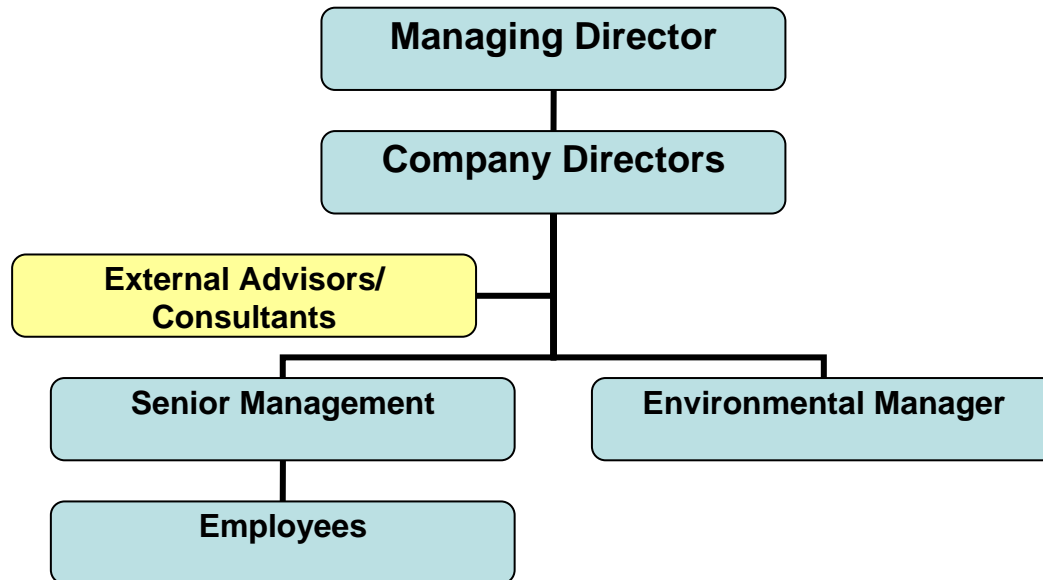

The effectiveness of the management of environmental issues is dependant on the persons who are responsible for ensuring that all aspects of work are carried out with due consideration for the environment.

Ultimate responsibility lies with the Directors, but specific duties are delegated to others according to their experience and training.

Company Directors and senior management, both individually and collectively, will ensure that this policy is applied throughout the company and that those employed by the company are kept fully informed of its content.

Managers will ensure that this policy is adopted by all employees, sub-contractors, suppliers and visitors. Furthermore every individual person has a duty of care.

To assist the company in fulfilling its duties and obligations, an external advisor/consultant may be appointed to provide advice and assistance to the management and employees of JT Automation Technology Ltd. Their contact details will be clearly displayed on the company notice board.

3.0 IMPLEMENTATION OF THE POLICY

Whilst overall responsibility for the implementation of this Policy is vested with the Company Directors, responsibility for the day to day application of the policy is delegated to the Director Responsible for Environmental Management.

To clarify the roles and responsibilities, the following duties have been allocated to nominated employees:

- Induction Training - Jamie Trump
- Environmental Impact/Risk Assessments - Jamie Trump
- Workplace Environmental Audits - Jamie Trump
- Waste Management - Jamie Trump
- Noise Assessments - Jamie Trump
- Air Emissions (Smoke, fumes, dust etc) - Jamie Trump
- Fuel and oil storage - Jamie Trump

The above named individuals will be responsible for ensuring that adequate consideration is given to each of the various issues, however, in many instances, specialist advice and support will be required to enable these individuals to ensure that a suitable and sufficient assessment of the issues has been undertaken.

All individuals are however expected to:

- take reasonable care for the protection of the environment through their own acts or omissions
- co-operate with others in the discharge of their duties
- work in accordance with all environmental procedures

At the planning stage, full account is to be taken of those factors that help to eliminate potentially harmful emissions/discharges, waste or other forms of pollution such as noise. Decisions about other priorities (e.g. programme and profit) are to take proper account of the environmental constraints that may be present.

Specific and precise arrangements will be developed and implemented, as needed, to enable the Policy and Procedures to be implemented. Safe systems of work, incorporating, where applicable, environmental reviews and risk assessments, are to be established, implemented and monitored to ensure the appropriate environmental standards are maintained at all times.

High standards will be applied when complying with legislation regarding the protection of the environment.

High standards of cleanliness, hygiene and housekeeping will be maintained at all times, while safe, adequate and clear means of access and egress to places of work will be provided and maintained.

All members of staff will be provided with appropriate and suitable personnel protective clothing and equipment, appropriate to the work which is to be undertaken. Full training and instruction in the use, maintenance and storage of such equipment will be provided to all members of staff.

All incidents, no matter how minor will be reported and recorded in the company's environmental incident log. Significant incidents will be promptly investigated to ensure that the appropriate preventative measures are implemented to prevent a recurrence as appropriate.

All such incidents should be reported to:

➤ **Environmental Manager**

Environmental training programmes will be promoted with the object of achieving personal awareness of the risks and hazards to the environment, associated with the works JT Automation Technology Ltd undertakes.

Responsibility and accountability in relation to the prevention of pollution, reduction of waste and protection of the environment will be specified clearly and in writing to all employees.

Arrangements for the implementation of this Policy are the responsibility of the company's Directors.

The Policy will be explained to all new staff as part of their induction training, before they start work, and a copy of the policy will be made available for reference by any member of staff.

An annual review of the Environmental Policy and Procedures Manual will be carried out to ensure that the procedures and controls remain valid and relevant to our work activities. Further reviews may be carried out as and when required. All updates and amendments to the documentation will be circulated to all Company Personnel.

4.0 ENVIRONMENTAL MANAGEMENT RESPONSIBILITIES

4.1 MANAGING DIRECTOR

The Managing Director has overall responsibility for the Environmental Policy and its implementation.

4.2 COMPANY DIRECTORS

All Directors will ensure that:

- The Company Environmental Policy is issued to all employees and that the written arrangements made to implement the policies are available to all employees
- All employees are made aware of their personal responsibilities
- Appropriate training, resources and support are available to all staff
- Environmental issues are given appropriate consideration
- They regularly liaise with the Environmental Manager
- Risks to the Company relating to potential incidents at work, environmental impacts, loss or damage to Company Property, and risks to the Public through Company activities are properly evaluated
- Liability is covered by insurance and advice given to the extent to which risks are acceptable, whether insured or not
- Environmental performance is recorded and reviewed periodically so as to advise when action is necessary to correct adverse trends

It is the responsibility of the directors to ensure the allocation of adequate finances and other resources for the effective implementation of the Environmental Management System. Key topics requiring specific resource allocation are: Management Representation; Training; Emergency response equipment; Monitoring and measuring equipment, and Record-keeping systems.

4.3 ENVIRONMENTAL MANAGER

The Environmental Manager is responsible for overseeing the management of environmental issues within the company, as follows:

- Report to the directors and keep them apprised on all matters regarding environmental management
- State the Company's Policies in writing with regard to environmental management, and ensure it is brought to the attention of all employees
- Ensure that arrangements are made for implementing the Company's Environmental Policy
- Ensure that environmental management data is collected, reviewed and reported on
- Ensure that the Company Procedures, Instructions and Guidance are regularly reviewed and amended as necessary
- Provide environmental advice to managers, employees and Customers, using, as necessary, specialist external advisors/consultants
- Promote positive environmental values throughout the Company

- Communicate effectively with external organisations such as the Environment Agency regarding the policy and its implementation
- Investigate environmental incidents and record all findings and make recommendations for the prevention of similar incidents
- Liaise with Procurement and Project Managers on contract standards and any future changes or additions required to the policy
- Monitor the effectiveness of the procedures by workplace inspections and audits and report on any improvements that may be required

4.4 SENIOR MANAGEMENT

Directors and Managers are at all times, responsible for implementation of the Company's Environmental Policy. All members of the senior management team shall:

- Understand the Company's Environmental Policy
- Set a personal example
- Identify and organise appropriate training for their staff
- Liaise with the company's Environmental Manager
- Actively promote a positive environmental culture throughout their areas of responsibility
- Ensure the Policy is implemented properly and that any delegated duties are correctly performed
- Ensure that all agreed actions are implemented as soon as practicable
- Suspend any activity, work or other activity which is considered to constitute an immediate danger to the environment. The circumstances should then be fully investigated and no work shall be allowed to continue until the appropriate remedial actions have been implemented.
- Ensure that regular Environmental inspections are carried out and that environmental issues are actively managed and controlled
- Ensure that the overall environmental performance of JT Automation Technology Ltd sites is discussed at regular intervals with all contractors, including sub-contractors
- Report any problems or improvements to this policy to the appropriate director
- Actively promote, at all levels, the Company's commitment to effective environmental management

4.5 ALL EMPLOYEES

All employees are required to:

- Understand the Company's Environmental Policy
- Co-operate with the Company in complying with duties and requirements imposed by relevant statutory provisions and Company Procedures
- Co-operate with the Company in complying with Environmental Management duties and requirements imposed by Management
- Not interfere with, or misuse anything provided in the interests of environmental protection
- Report all environmental incidents to your Manager

Section Two

Environmental Management Procedures

ENVIRONMENTAL PROCEDURES

This section details the arrangements and procedures that we will use to help implement our Environmental Management Policy and ensure compliance with current Environmental Legislation.

Within the procedures, reference is made to the 'Project Environmental Management Plan'. This is a project specific document which should be prepared for all new projects and it should detail the project specific arrangements and constraints for the management of all environmental issues on the site.

AIR POLLUTION

PURPOSE

The purpose of this procedure is to provide guidance and assistance with the development and production of project specific procedures with regards to air pollution for inclusion in a Project Specific Environmental Management Plan.

SCOPE

This procedure applies to all JT Automation Technology Ltd personnel and operational activities. The responsibilities for implementing the procedure are outlined below.

Site Manager

- Overall responsibility for air pollution control on site
- Develop section of the Project Environmental Management Plan to include air pollution control
- Ensure all sub-contractors and suppliers abide by air pollution control guidelines
- Liaise with the Environmental Manager for all air pollution control issues

Environmental Manager

- Assist Site Managers in the development of the Project Environmental Management Plan regarding the control of air pollution
- Ensure all staff comply with the air pollution control procedures

PROCEDURES

Operational Control Guidelines

1. Any requirements for air quality monitoring throughout the project must be identified prior to the commencement of any works.
2. All activities which may cause air pollution should be highlighted and specific risk assessments and safe systems of works should be prepared.
3. All operations are to be carefully planned and managed to ensure that impacts are kept to a minimum.
4. All plant and equipment will be chosen and serviced regularly to minimise emissions.
5. Where air monitoring is carried out, all records will be retained for a minimum period of 12 years.
6. All permanent and temporary employees, including sub-contractors and suppliers, will be made aware of their responsibilities to ensure that no air pollution incidents occur.
7. In the event of an air pollution incident, the Emergency Control Procedures outlined below will be followed.

Emergency Control Procedures

1. In the event that excessive dust is arising from operations on site due to plant or traffic movements, then damping down of the roads and surrounding area shall be used to control the dust. Road sweepers shall also be used to keep roads clean and tidy where appropriate.
2. If the problem persists it may be necessary to install wheel-washing systems.
3. Where dust is arising from excavations, water shall be applied across the working area.
4. Where dust is arising from stockpiles of materials, water shall be applied to the stockpile, or the stockpiles should be sheeted.
5. Care shall be taken in both instances where water is being applied to the soil to prevent excessive run-off causing a further pollution incident, or a safety hazard due to the weakening of the ground.
6. If any item of plant is releasing excessive emissions through its exhaust, it should be turned off, returned to the hire firm and replaced with better quality plant.
7. Where emissions are becoming a problem during cutting the method of working will be changed to use damping or extractive techniques.
8. Should any excessive odours arise from storage areas including fuel, chemicals and waste the cause should be investigated and changes made to storage arrangements.
9. Waste must be regularly collected and removed from site to prevent odour emissions.
10. In the event that a serious environmental incident occurs, contact the company's Environmental Manager and advise the Environment Agency using the 24 hour Emergency line - **0800 80 70 60**

CONTAMINATED LAND

PURPOSE

The purpose of this procedure is to provide guidance and assistance with the development and production of project specific procedures with regards to contaminated ground for inclusion in a Project Specific Environmental Management Plan.

SCOPE

This procedure applies to all JT Automation Technology Ltd personnel and operational activities. The responsibilities for implementing the procedure are outlined below.

Site Manager

- Overall responsibility for prevention and control of known contaminated land issues on site
- Develop section of the Project Environmental Management Plan to include prevention and control of known land contamination
- Ensure all sub-contractors abide by contaminated land guidelines
- Liaise with the Environmental Manager for all contaminated land issues

Environmental Manager

- Assist Site Managers in the development of the Project Environmental Management Plan regarding the prevention and control of land contamination issues
- Ensure all staff comply with the contaminated land guidelines

PROCEDURES

Operational Control Guidelines

1. Any areas of contaminated land must be identified from the site investigation data and contract documents so that its treatment and/or disposal can be managed.
2. If additional sampling or testing is required, this must be identified prior to the commencement of any works.
3. All operations involving contaminated land must be clearly identified and project specific risk assessments and method statements must be prepared.
4. If contaminated materials are stored on site, the method of containment must prevent any escape of dust, leachate or other substances.
5. Disposal of contaminated materials off site must be to licensed sites and in accordance with the Duty of Care.
6. All permanent and non-permanent employees, including sub-contractors, must be made aware of their responsibilities to ensure that contaminated land is unable to cause further pollution.

7. In the event that contaminated land causes further pollution then the Emergency Control Procedures stated below must be followed.

Emergency Control Procedures

1. When dealing with known contaminated land and 'run-off' is becoming a problem the Emergency Control Procedures for water pollution must be followed.
2. When dealing with known contaminated land and dust generation is becoming a problem the Emergency Control Procedures for air must be followed.
3. In addition to this all operatives in the area must be issued with dust masks to prevent ingestion of the contaminated materials.
4. Stop work immediately, seal off the area, and report to the Site Manager in the event that one or more of the following are found:
 - Discoloured or oily soil (chemical or oil residues)
 - The soil has a fibrous texture (asbestos)
 - Presence of foreign objects (chemical/oil containers)
 - Evidence of underground structures and storage tanks
 - Existence of waste pits
 - Old drain runs and contamination within building and tanks
5. The contaminated materials must be tested at an approved laboratory to ascertain what hazards may be presented by the substance.
6. Following the receipt of the laboratory results a project specific method statement and risk assessment must be prepared to dispose of/deal with the material. Approval will be needed from the Environment Agency and the Environmental Manager.
7. In the event that a serious environmental incident occurs, contact the company's Environmental Manager and advise the Environment Agency using the 24 hour Emergency line - **0800 80 70 60**

ECOLOGY, ARCHAEOLOGY AND CULTURAL HERITAGE

PURPOSE

The purpose of this procedure is to provide guidance and assistance with the development and production of project specific procedures with regards to ecology, archaeology, and cultural heritage for inclusion in a Project Specific Environmental Management Plan.

SCOPE

This procedure applies to all JT Automation Technology Ltd personnel and operational activities. The responsibilities for implementing the procedure are outlined below.

Site Manager

- Overall responsibility for ecology, archaeology, and cultural heritage on site
- Develop section of the Project Environmental Management Plan to include ecology, archaeology, and cultural heritage
- Ensure all sub-contractors comply with the ecology, archaeology, and cultural heritage guidelines
- Liaise with the Environmental Manager on all ecology, archaeology, and cultural heritage issues

Environmental Manager

- Assist Site Managers in the development of the Project Environmental Management Plan ecology, archaeology, and cultural heritage issues
- Ensure all staff comply with the ecology, archaeology, and cultural heritage guidelines

PROCEDURES

Operational Control Guidelines

1. Any contractual requirements for the preservation, monitoring and management of ecology, archaeology and cultural heritage issues must be prior to the commencement of any works.
2. All areas where ecological, archaeological and cultural heritage issues exist should be highlighted in the Project Environmental Management Plan.
3. Specific risk assessments and method statements must be completed for all operations that may impact on sensitive parts of the site. This is to ensure that all such operations are properly managed and controlled.
4. The Site Manager is responsible for liaising with English Heritage and other interested parties to ensure that no issues are overlooked when planning potentially disruptive works.

5. Strict controls shall be implemented where necessary to ensure that any persistent vegetation such as Japanese Knotweed is not allowed to spread around or off of the site.
6. All permanent and non-permanent employees, including sub-contractors, will be made aware of their responsibilities to ensure that damage to ecology, archaeology and cultural heritage is minimised.
7. In the event that damage to ecology, archaeology and cultural heritage occurs then the Emergency Control Procedures below should be followed.

Emergency Control Procedures

1. In the event that damage to any ecology, archaeology and cultural heritage occurs work must be stopped immediately.
2. The incident must be reported to the Site Manager.
3. The area should then be protected using Heras type fencing or similar.
4. Specialist advice should be sought from relevant organisations such as English Nature or English Heritage.
5. The Environmental Manager must be notified.
6. Special consent may be required before work can recommence from the relevant authority.
7. The reason for the problem occurring must be investigated and any changes made to future operations and programmes.
8. In the event that a serious incident occurs, contact the company's Environmental Manager.

NOISE AND VIBRATION

PURPOSE

The purpose of this procedure is to provide guidance and assistance with the development and production of project specific procedures with regards to noise and vibration for inclusion in a Project Specific Environmental Management Plan.

SCOPE

This procedure applies to all JT Automation Technology Ltd personnel and operational activities. The responsibilities for implementing the procedure are outlined below.

Site Manager

- Overall responsibility for control of noise and vibration on site
- Develop section of the Project Environmental Management Plan to include prevention and control noise and vibration
- Ensure all sub-contractors abide by noise and vibration guidelines
- Liaise with the Environmental Manager for all noise and vibration issues

Environmental Manager

- Assist Site Managers in the development of the Project Environmental Management Plan for environmental noise and vibration issues
- Ensure all staff comply with the noise and vibration guidelines

PROCEDURES

Operational Control Guidelines

1. Requirements regarding the control of noise and vibration levels should be identified so that the appropriate control measures can be implemented.
2. The company's environmental policy and procedures will be taken into account when selecting plant and equipment and when developing safe systems of work.
3. Where it has been identified that buildings and services may be affected by noise and vibration, all necessary control measures are to be highlighted within applicable safe systems of work.
4. In sensitive areas, such as urban and commercial districts, liaison with the Environmental Health Officer will be needed to ensure that noise and vibration levels are maintained within permissible levels.
5. Noise emissions should be regularly monitored and recorded as deemed appropriate.
6. Where necessary vibration will be monitored to ensure that no structural damage is being caused to adjacent buildings and services.

7. Local residents and businesses are to be kept informed of when activities producing excessive noise and vibration are to take place.
8. All operations should be sequenced, where appropriate, to minimise the generation of noise and vibration, and where practical, plant and material stockpiles should be located to absorb noise emissions.
9. Where appropriate, prior consent will be sought from the local authority under Section 61 of the Control of Pollution Act 1974.
10. All employees, sub-contractors and suppliers will be made aware of their responsibilities and duties to ensure that noise and vibration generated by them is correctly managed and controlled.
11. In the event that noise and vibration emissions exceed permissible levels, then the following Emergency Control Procedures are to be followed.

Emergency Control Procedures

1. In the event of noise and vibration limits being exceeded the work or activity causing the noise/vibration is to be stopped.
2. Where appropriate plant is to be re-orientated to re-direct emissions away from sensitive receptors.
3. Where appropriate material is to be stockpiled to provide a noise barrier to absorb noise emissions.
4. Where appropriate erect additional noise barriers.
5. If these steps are unsuccessful in reducing emissions to an acceptable level then working practices and arrangements will be changed accordingly.
6. Monitoring shall take place throughout the operation to ensure compliance.

SUSTAINABLE DEVELOPMENT

PURPOSE

The purpose of this procedure is to provide guidance and assistance with the development and production of project specific procedures with regards to sustainable development for inclusion in a Project Specific Environmental Management Plan.

SCOPE

This procedure applies to all JT Automation Technology Ltd personnel and operational activities. The responsibilities for implementing the procedure are outlined below.

Site Manager

- Overall responsibility for control of on site sustainable development issues
- Develop section of the Project Environmental Management Plan to include control of sustainable development
- Ensure all sub-contractors abide by the sustainable development guidelines
- Liaise with the Environmental Manager for all sustainable development issues

Environmental Manager

- Assist Site Managers in the development of the Project Environmental Management Plan regarding the control of resource consumption
- Ensure all employees are abiding by sustainable development guidelines

PROCEDURES

Operational Control Guidelines

1. All timber including temporary works should, wherever practical, be from a temperate sustainable resource and certified as such from an independent inspection agency accredited by the Forest Stewardship Council (FSC).
2. Peat is not to be imported for use as a soil conditioner for landscaping or planting.
3. Imported soil conditioners will be free from peat and be produced from recycled and renewable materials free from weed seeds, disease and fungal organisms.
4. All materials will be accurately ordered to minimise waste.
5. Where possible the use of recycled materials and other environmentally friendly options should be investigated.
6. During construction the work area will be kept tidy to minimise the risk of damage to materials.
7. All operations will be adequately supervised to ensure that the wastage is kept to a minimum.

8. All plant and office equipment will be turned off when not in use to conserve power/fuel.
9. Where possible the consumption of stationery in all offices will be used conservatively.
10. Waste paper and empty toner cartridges will be recycled.

STATUTORY NUISANCE

PURPOSE

The purpose of this procedure is to provide guidance and assistance with the development and production of project specific procedures with regards to statutory nuisance for inclusion in a Project Specific Environmental Management Plan.

DEFINITION

Although there is no legal definition of a statutory nuisance, for action to be taken, the nuisance must, or be likely to be prejudicial to a persons health, or interfere with a persons legitimate use and enjoyment of land. This particularly applies to nuisance to neighbours in their homes, offices and gardens.

A statutory nuisance could arise from the poor state of the company's premises or sites, or from any noise, smoke, fumes, gases, dust, steam, smell, effluvia, the keeping of animals', deposits and accumulations of refuse and/or other material, and other discharges from company premises.

SCOPE

This procedure applies to all JT Automation Technology Ltd personnel and operational activities. The responsibilities for implementing the procedure are outlined below.

Site Manager

- Overall responsibility for control of statutory nuisance on site
- Develop section of the Project Environmental Management Plan to include prevention and control of statutory nuisance
- Ensure all sub-contractors abide by statutory nuisance guidelines
- Liaise with the Environmental Manager for all statutory nuisance issues

Environmental Manager

- Assist Site Managers in the development of the Project Environmental Management Plan for statutory nuisance issues
- Ensure all staff comply with the statutory nuisance guidelines

PROCEDURES

Operational Control Guidelines

1. The procedures for air pollution, contaminated land, noise and vibration, and water pollution should be followed to prevent any statutory nuisance in these forms.
2. If the site is located adjacent to residential areas then any lighting that is required is to be located to minimise disruption through glare or light pollution.

3. All complaints from local residents are to be collated and where appropriate procedures developed to prevent any recurrence.
4. In the event of an incident involving statutory nuisance the Emergency Control Procedures below must be followed.

Emergency Control Procedures

1. Should any incident surrounding statutory nuisance occur, the appropriate operational procedures, as identified above, must be followed.
2. All complaints shall be recorded and the Environmental Manager shall be notified.
3. Where problems occur regarding site lighting then the lighting shall be relocated to reduce the impact upon the surrounding residents and neighbours.

TRAFFIC MANAGEMENT

PURPOSE

The purpose of this procedure is to provide guidance and assistance with the development and production of project specific procedures with regards to traffic management for inclusion in a Project Specific Environmental Management Plan.

SCOPE

This procedure applies to all JT Automation Technology Ltd personnel and operational activities. The responsibilities for implementing the procedure are outlined below.

Site Manager

- Overall responsibility for traffic management on site and for liaising with the local highway authorities
- Develop the Project Environmental Management Plan to include traffic management proposals
- Ensure all sub-contractors abide by traffic management requirements
- Liaise with the Environmental Manager for all traffic management issues

Environmental Manager

- Assist Site Managers in the development of traffic management proposals for the Project Environmental Management Plan
- Ensure all staff comply with the statutory nuisance guidelines

PROCEDURES

Operational Control Guidelines

1. All traffic management issues identified in the contract documents must be incorporated into the Project Environmental Management Plan.
2. Where appropriate, arrangements for the delivery of materials should take place outside peak hours.
3. All access roads should be regularly monitored for damage and deposition of mud and debris, where mud and debris are found to be a problem, all debris should be quickly removed and the roads kept clean and tidy.
4. All plant should be regularly serviced to ensure that it does not cause excessive pollution and operates safely and efficiently.
5. In the event that a traffic management problem occurs the Emergency Control Procedures below should be followed.

Emergency Control Procedures

1. In the event that the increased numbers of traffic movements adjacent to the site cause problems with congestion, road conditions or noise, then measures should be implemented to minimise them.
2. Where congestion is occurring at the beginning and end of the day, the use of flexible working hours and staggered starting times should be considered.
3. Where excess mud and debris is being deposited on local roads around the site, the incorporation of wheel washes and use of road sweepers should be considered.

WASTE MANAGEMENT

PURPOSE

The purpose of this procedure is to provide guidance and assistance with the development and production of project specific procedures with regards to waste management for inclusion in a Project Specific Environmental Management Plan.

SCOPE

This procedure applies to all JT Automation Technology Ltd personnel and operational activities. The responsibilities for implementing the procedure are outlined below.

Site Manager

- Overall responsibility for waste management on site
- Develop section of the Project Environmental Management Plan to include the management of waste, including the segregation of waste and the use of recycling initiatives
- Where applicable develop and manage the Site Waste Management Plan (SWMP)
- Ensure all sub-contractors abide by waste management guidelines
- Liaise with the Environmental Manager for all waste management issues

Environmental Manager

- Assist Site Managers in the development of waste management proposals for the Project Environmental Management Plan
- Ensure all staff comply with the waste management guidelines

PROCEDURES

Office Waste Guidelines

1. All consumables and office supplies are to be used conservatively, including the recycling and reuse of supplies where practical.
2. Company paper is only to be used for business purposes and waste paper should be recycled rather than disposed of.
3. The use of double-sided copying and printing should be made wherever practical.
4. Scrap paper will be reused for draft printing whenever possible.
5. Office paper supplies will be discarded separately into segregated and designated recycling bins. All cardboard materials will be discarded separately into respective segregated bins. All other rubbish will be discarded in the normal manner.

OPERATIONAL CONTROL GUIDELINES

1. All work shall be carefully considered and implemented to minimise the generation of waste.
2. Where it has been identified that wastes are to be produced, or potentially produced, by a new project or activity, this will be clearly identified prior to the commencement of the work.
3. Specialist disposal requirements including any Waste Management License issues will be identified prior to commencement.
4. All employees, including sub-contractors will be requested to identify the types of waste that can be reduced, reused, or re-cycled on-site or off-site.
5. All employees, suppliers and sub-contractors will be made aware of their responsibilities to ensure the correct disposal of waste.
6. Where the production of hazardous wastes is envisaged, the Site Manager will liaise with the Environmental Manager and the appropriate Environment Agency office to determine the most appropriate method of disposal.
7. All sites producing hazardous waste must be licensed with the Environment Agency.
8. Waste disposal contractors must possess the appropriate license to dispose of the waste from site. The site manager should periodically check the waste contractor's current license.
9. All waste disposal operations shall comply with the Duty of Care. A Waste Transfer Note/Consignment Notice will accompany all waste transfers. The Waste Transfer Note must be retained for a minimum of three years.
10. The storage requirements for wastes are to be identified to allow for the segregation of the waste and the prevention of odours, water pollution and the cross contamination of materials.
11. In the event of the escape of waste the Emergency Control Procedures below must be followed.

Emergency Control Procedures

Liquid Waste

1. In the event of liquid waste escaping the site manager is to be notified.
2. The Site Manager is to notify the Environmental Manager and the appropriate Environment Agency office.
3. Stop the flow of pollution using earth, sand or polythene and divert away from drains and watercourses.

4. Deploy spill kits as necessary to contain and absorb the spill.
5. Contaminated sand, earth or granules must be disposed of as contaminated material
6. The reasons and cause of the escape must be thoroughly investigated, and recommendations made to prevent a reoccurrence.

Solid Waste

1. In the event of solid waste escaping the Site Manager is to be notified.
2. The waste that has escaped must be collected and placed into a secure skip.
3. Depending on the hazard presented by the material, specific personal protective equipment may be required.
4. The reasons and cause of the escape must be thoroughly investigated, and recommendations made to prevent a reoccurrence.

Odours from Waste

1. In the event that odours become a problem from waste storage, the skips must be emptied immediately.
2. If similar waste is likely, then covered skips must be used and emptied regularly.

WATER POLLUTION

PURPOSE

The purpose of this procedure is to provide guidance and assistance with the development and production of project specific procedures with regards to water pollution for inclusion in a Project Specific Environmental Management Plan.

SCOPE

This procedure applies to all JT Automation Technology Ltd personnel and operational activities. The responsibilities for implementing the procedure are outlined below.

Site Manager

- Overall responsibility for prevention of water pollution on site
- Develop section of the Project Environmental Management Plan to include water pollution
- Ensure all sub-contractors abide by the water pollution guidelines
- Liaise with the Environmental Manager and respective Environmental Agency for all water pollution issues

Environmental Manager

- Assist Site Managers in the development of water pollution proposals for the Project Environmental Management Plan
- Ensure all staff comply with the water pollution guidelines

PROCEDURES

JT Automation Technology Ltd will ensure that no contamination of adjacent watercourses and the groundwater will occur as a result of their operations. This will also include minimising the impact of operations upon wildlife habitats, aquatic flora and fauna, fisheries, recreation and amenity facilities and landscape features.

JT Automation Technology Ltd will ensure that any operations that may pose a threat to these areas are carefully planned and managed to minimise the risk of pollution and environmental damage.

Operational Control Guidelines

1. Water quality sampling requirements must be identified and implemented prior to the commencement of any works.
2. The requirement for discharge consents to watercourses, surface water drains or foul drains must also be identified as soon as possible.
3. All watercourses and drainage systems adjacent to the site are to be highlighted in the Project Environmental Management Plan.

4. Suitable storage areas should be prepared to ensure that the quality of surface water and ground water is not put at risk.
5. If appropriate, the need for concrete wash out points will be identified and established on site.
6. All operations that are to take place in, above or adjacent to watercourses will be clearly identified, with specific risk assessments and safe systems of work being established prior to the commencement of any work.
7. All operations taking place in, above or near watercourses must be strictly supervised and monitored to ensure that no pollution incidents occur.
8. All permanent and temporary employees, including sub-contractors, are to be made aware of their responsibilities to ensure that no water pollution incidents occur.
9. In the event that a water pollution incident occurs then the Emergency Control Procedures below must be followed.

Emergency Control Procedures

1. All spillages, including fuel, oils, chemicals and silty run-off, must be reported to the Site Manager.
2. Where appropriate, the Site Manager must notify the Environmental Manager and the appropriate Environment Agency office.
3. The source of pollution must be identified and the flow should be stopped or diverted using spill kits, earth, sand or polythene and diverted away from all drainage systems and watercourses.
4. Where flammable substances are involved, any adjacent sources of ignition must be switched off.
5. An absorbent boom must be placed across watercourses to contain and absorb any spills.
6. Spillages must not be washed into drainage systems or watercourses and detergents must not be used.
7. All absorbent materials used to soak up the spill must be disposed of as contaminated material.
8. The incident is to be investigated with the Environmental Manager. The reasons and cause of the escape must be thoroughly investigated, and recommendations made to prevent a reoccurrence.
9. Details of the investigation and any changes to working practices will be reported to the Environmental Manager and where appropriate to the Environment Agency.

10. In the event that a serious environmental incident occurs, contact the company's Environmental Manager and advise the Environment Agency using the 24 hour Emergency line - **0800 80 70 60**

DELIVERY, STORAGE, REFUELLING AND SPILLS OF FUEL AND CHEMICALS

PURPOSE

The purpose of this procedure is to provide guidance and assistance with the development and production of project specific procedures with regards of the delivery, storage, refuelling, and spillage of fuel and chemicals.

SCOPE

This procedure applies to all JT Automation Technology Ltd personnel and operational activities. The responsibilities for implementing the procedure are outlined below.

Site Manager

- Overall responsibility for the control of fuel and chemicals on site
- Development of a specific section for the Project Environmental Management Plan to address the delivery, storage, refuelling, and spills of fuel and chemicals
- Ensure all sub-contractors abide by these guidelines
- Liaise with the Environmental Manager on all issues regarding the delivery, storage, refuelling, and spills of fuel and chemicals

Environmental Manager

- Assist Site Managers in the development of procedures for the delivery, storage, refuelling, and spills of fuel and chemicals, for the Project Environmental Management Plan
- Ensure all staff comply with the guidelines

PROCEDURES

DELIVERIES

All deliveries will be supervised by a competent person capable of dealing with any spills or other incidents that may occur. The level of all storage tanks will be checked before delivery to prevent overfilling and to ensure that the product is delivered to the correct tank.

STORAGE

Fuel, oil and chemical tanks must be sited on an impervious base, within a secure bund. The base and bund must be impermeable to the substance being stored and have sufficient capacity for daily use and for the receipt of additional deliveries. Leaking, damaged or empty tanks/drums must be removed from the site immediately and disposed of via a licensed waste disposal contractor. All bowsers must be banded to prevent any accidental spills.

All tanks and containers shall be stored in a secure, locked area, protected from vandalism, and clearly marked with the contents of the substance. To help limit the

impact of any spills, all such storage areas should be located at least 10 metres from any drain or watercourse.

Where large quantities of fuel or oil are to be stored on-site, the above ground storage tank should be constructed to the relevant British Standard. The bund should be constructed to contain 110% of the capacity of the storage tank and monitored regularly for any build up of rainwater. Any rainwater from within the bund must be treated as contaminated waste and should be appropriately disposed of appropriately to eliminate the potential for further pollution. The diagram below highlights the features that are required for the correct storage of fuels and oils.

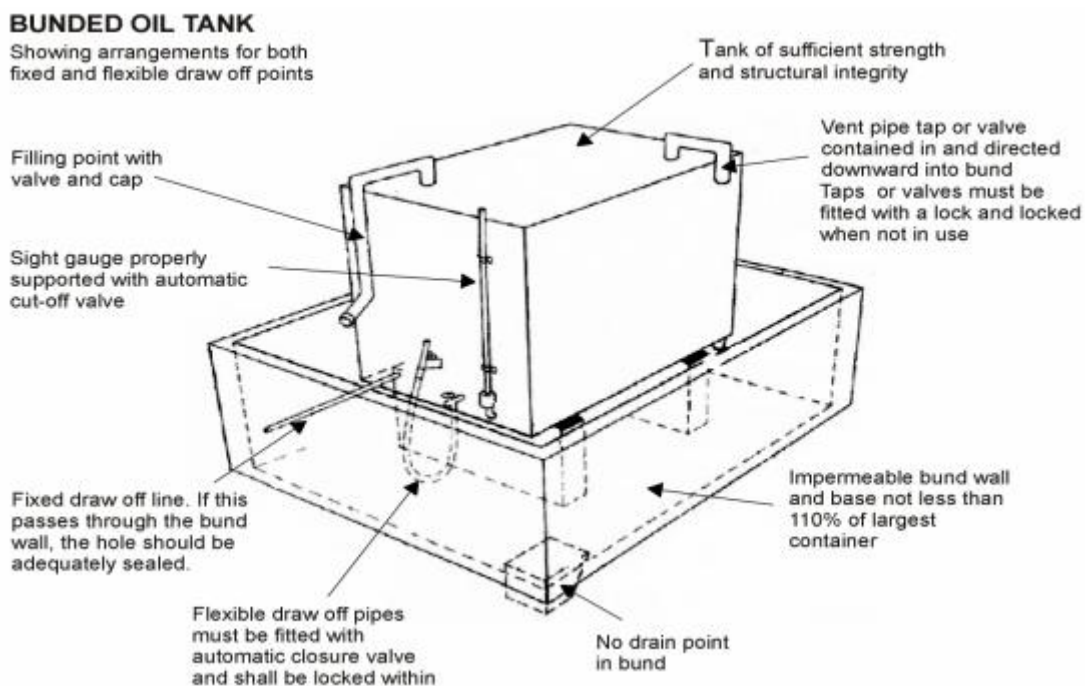

SECURITY

All valves and trigger guns must be protected from vandalism and unauthorised use. When not in use they should be turned off and securely locked. Any tanks or drums should be stored in a secure container or compound, which should be kept locked when not in use. Bowsers must also be stored within secure compounds when not in use.

REFUELLING

All mobile plant will be refuelled in designated areas on an impermeable surface and away from drains, a spill kit will be available at all times

USE OF PLANT

All fuel operated plant and equipment shall be operated within strict controls, including the use of drip trays to contain any leaks or overflow etc.

SPILLS

Spill kits and absorbent booms shall be available on site, where a risk assessment recommends this, to ensure that in the event of a spillage the environmental impacts are kept to a minimum. In the event of a spillage occurring, this equipment shall be used to help minimise any environmental damage prior to the implementation of more comprehensive solutions. Nominated members of staff will be trained to use and deploy the spill kits in the event of an incident. In a serious emergency, where the spill kits are to be of no use, the Environment Agency, fire service and ambulance service shall be contacted as necessary dependent on the consequences of the spill. Any method statements shall identify emergency procedures for each operation.

Plant such as mobile generators shall be used in conjunction with drip trays to contain any leaks and overflows.

ENVIRONMENTAL IMPACT/RISK ASSESSMENTS

A key element of the Environmental Protection Act 1990 is to identify the impacts our business operations have on our surrounding environment. The environmental impacts of all work carried out by JT Automation Technology Ltd will be assessed prior to the commencement of any operations which may have an adverse impact on the environment. These assessments will be monitored and reviewed on an annual basis and amended where appropriate to cater for the requirements of specific projects.

All senior managers should consider the impact their operations have on the environment and raise a formal environmental risk assessment using the template provided in Section 3 of this Manual. Guidance covering the areas and elements to be considered within such risk assessments should be drawn from the contents of this Manual, the contract documentation and any site specific requirements.

Sub-contractors and other staff working for JT Automation Technology Ltd should make themselves aware of any assessments that have been undertaken to address the activities that they are carrying out. Any actions that are required to keep these assessments valid and relevant must then be followed.

The basic stages to be adopted when carrying out an environmental risk assessment are as follows:

Stage 1: Hazard identification

Guidance defines a *hazard* as a “property or situation that in particular circumstances could lead to harm”. This may be determined by properties or circumstances and could include, for example, the release of chlorofluorocarbons (CFCs); a tidal surge along a stretch of the coast; a dry summer leading to low river flows; or the planting of a genetically modified crop. Where risk assessments are to be applied, the hazards may be as broad as the adverse impacts of road transport on the environment, or the adverse impacts of induced climate change from the contribution of fossil fuel-derived carbon dioxide emissions.

The identification of relevant hazards will therefore have an important bearing on the overall assessment and the credibility of the final assessment.

One common pitfall in establishing the hazards is to overlook secondary hazards that may arise. For example, during a river flood, sediments may be deposited within the working area. If these sediments were to be contaminated, they might pose an additional hazard.

Stage 2: Identification of consequences

The potential consequences that may arise from any given hazard are inherent to that hazard. Although the full range of potential consequences must be considered at this stage, no account is taken of likely exposure and therefore likely consequences. For example, while the potential consequences of a discharge of toxic metals to a watercourse may be self-evident, a flood may have additional, non-obvious consequences such as pollution arising from an over-stretched sewerage system, or loss of habitats due to river scouring.

These examples help to highlight why it is necessary to take a broad look at the potential environmental damage that may occur, if only to be clear why some potential consequences are rejected for further assessment.

Stage 3: Estimation of the severity of consequences

The consequences of a particular hazard may be actual or potential harm to human health, property or the natural environment. The severity of such consequences can be determined in different ways depending on whether they are being considered as part of a risk screening process, or as part of a more detailed quantification of risk. At all stages of risk assessment several key features need to be considered, as described below.

The spatial scale of the consequences

The geographical scale of harm resulting from an environmental impact will often extend considerably beyond the boundaries of the source of the hazard. Failure to consider this at an early stage may result in the scope of the risk assessment being too limited. For example, a major accident in a chemical plant is likely to have significant effects on the environment well beyond the perimeter of the site.

The temporal scale of the consequences

The duration of the harm that results may be so prolonged that the damage can be assumed to be permanent and the environment beyond recovery. For example, the release of a genetically modified crop could result in extensive cross-breeding with adjacent indigenous flora, any harmful environmental impacts could extend far into the future.

The time to onset of the consequences

A further factor to consider is how quickly harmful effects might be seen. Standard economic techniques tend to discount impacts that will happen in the future but sustainable development emphasises the need to protect the interests of future generations. Risk assessment and management must therefore pay as much attention to long-term problems as to the more immediate risks. For example, the spillage of a solvent on porous ground may not result in an impact on the underlying aquifer for decades. However, once realised, the duration of the harm is likely to be of the order of decades and will compromise the value of that aquifer as a source of water for future generations.

Stage 4: Estimation of the probability of the consequences

The above stages have assumed that realisation of the hazard will lead to environmental harm. However, the probability or likelihood of the consequences occurring must also be taken into account. This has three components:

The probability of the hazard occurring

The probability of the receptors being exposed to the hazard

The probability of harm resulting from exposure to the hazard

Stage 5: Evaluating the significance of a risk

Having determined the likelihood and severity of the consequences that may arise as a result of the hazard, it is important to place them in some sort of context. It is at this point that some value judgements are made, either through reference to some pre-existing measure, such as an environmental quality standard or flood defence standard, or by reference to social, ethical, or political standards.

Options appraisal

Having estimated the magnitude and the significance of the risks posed by the hazard(s), the options for risk management are identified and evaluated. It is important to carry out this procedure as a distinct preliminary step because ill-considered risk management strategies may otherwise result in wasted effort and expenditure on the part of the decision-maker. The options that will usually be available are:

- exploring the acceptability, or otherwise, of the risk - this can include rejecting unacceptable risks altogether or accepting the risk being imposed;
- reducing the hazard through new technology, procedures or investment; or
- mitigating the effects, through improved environmental management techniques.

The decision on precisely which option or combination of options to choose will involve a balance of risk reduction, costs, benefits and social considerations.

ENVIRONMENTAL PERFORMANCE MONITORING AND REVIEW

The Environmental Manager will review the company's environmental performance and the effective implementation of the environmental management policy. The annual review shall cover:

- I. Environmental management monitoring results.
- II. Environmental management inspection results
- III. Comparison with the objectives stated in the previous review.
- IV. Effects and requirements of new legislation or changes to best practice guidance.

Irrespective of time periods, a review shall be conducted in the event of:

- I. Significant environmental incident.
- II. Incidence of Environment Agency enforcement action.
- III. Major change to environmental management arrangements or company activities.

ENVIRONMENTAL MANAGEMENT INFORMATION

The company will periodically purchase and maintain a selection of key environmental management documents and reference material for use by its staff and employees. These will be retained within the company's offices and requests for additional material shall be made via the Environmental Manager.

An Environmental Management notice board will be erected within the company offices and copies of all Environmental Alerts/Notices and other environmental related information shall be displayed on the notice board.

SITE WASTE MANAGEMENT PLANS (SWMP'S)

Each year the construction industry disposes of over 130 million tonnes of solid waste to landfill, while the Government is also concerned about the amount of waste that is being illegally fly-tipped.

Therefore in an attempt to reduce the volume of construction waste, the government introduced, on the 6th April 2008, a requirement for Site Waste Management Plan's (SWMP) for larger construction projects. The aim of the SWMP is to reduce the amount of waste produced on construction sites and to prevent fly-tipping by raising the profile of waste planning and recycling.

The requirements for a SWMP apply to all construction projects with a value greater than £300K. For these purposes the cost is the price in the accepted tender or, if there is no tender, the cost of labour, plant and materials, overheads and profit.

What should a SWMP contain?

A site waste management plan must identify:

- (a) the client;
- (b) the principal contractor; and
- (c) the person who drafted it.

The SWMP must describe the construction work proposed, including:

- (a) the location of the site; and
- (b) the estimated cost of the project.

The SWMP must record any decision taken before the SWMP was drafted, on the nature of the project, its design, construction method or materials employed in order to minimise the quantity of waste produced on site.

The SWMP must:

- (a) describe each waste type expected to be produced in the course of the project;
- (b) estimate the quantity of each different waste type expected to be produced; and
- (c) identify the waste management action proposed for each different waste type, including re-using, recycling, recovery and disposal.

It must contain a declaration that the client and the principal contractor will take all reasonable steps to ensure that:

- (a) all waste from the site is dealt with in accordance with the waste duty of care in section 34 of the Environmental Protection Act 1990 and the Environmental Protection (Duty of Care) Regulations 1991; and
- (b) materials will be handled efficiently and waste managed appropriately.

The SWMP will be a live document that is updated and added to on a daily basis as the site works are progressed, it must contain a full record of the waste generated on the site and detail what has happened to it, who has been involved in the processing of it and even what could have been done differently. For projects with a value in excess of

£500K the SWMP will be required to contain more in-depth information and detail on the proposals, including the disposal of the waste materials.

Furthermore, the SWMP must also be updated after the completion of the works to show what lessons have been learnt and how they will be applied to future projects, the SWMP must then be retained for a further 2 years following the completion of the project.

A detailed SWMP Template can be downloaded from the WRAP Website, alternatively a simple template is provided in the attached appendices.

Section Three

Miscellaneous Forms

ENVIRONMENTAL AUDIT CHECKLIST

ENVIRONMENTAL AUDIT CHECKLIST

Project:	Project No:
Client:	Date:

ITEM	SATISFACTORY			ACTION REQUIRED TO RECTIFY DEFICIENCIES	PRIORITY
	Y	N	N/A		
Site Security					
Complaints					
Waste Management					
Cleaning Operations					
Hazardous Wastes					
Chemicals & Fuels					
Water Pollution Prevention					
Pollution Response					
Dust & Air Pollution					
Light Pollution					
Noise & Vibration					
Visual Impact					
Permits, licences & consents					
Nature conservation & countryside protection					
Heritage & archaeology					

The following guidance is designed to highlight some of the environmental aspects that should be considered when completing the Environmental Audit Checklist.

ITEM	POINTS TO CONSIDER
Site Security	Integrity of perimeter fencing; gates; lighting and signage. Ensure that the keys are removed from all plant; liaise with police/council; check alarm systems and ensure that the client's security arrangements are in place.
Complaints	Check with the site manager and client to determine if any environmental complaints have been received from local residents or other interested parties.
Waste Management	Ensure all wastes are properly stored in segregated skips and check to see if storage containers are leaking or overflowing. Skips and other receptacles should be covered to prevent any accumulation of rainwater and to help prevent waste from being blown away. Ensure waste is being properly disposed of and that copies of the Waste Transfer Notes are available.
Cleaning Operations	Where cleaning activities could result in contaminated effluent or chemicals draining into any foul or surface water sewer; ensure that appropriate arrangements are in place to prevent any such contamination and that the area is properly bunded and drains are clear of debris.
Hazardous Waste	These include waste oils, solvents, acids, wood preservatives and batteries. Ensure hazardous wastes are properly stored; ensure that all hazardous waste is disposed of by authorised persons / authorities; Check Waste Transfer/Consignment Notes are in place.
Chemicals & Fuels	Ensure all such substances are stored within bunded areas, the bund should contain 110% of the maximum volume of the container/tank. Drip trays should be used to catch any drips or leaks from portable equipment and spill kits must be provided near storage and refuelling points. Check for leaks or damage to bunds and containers and ensure the storage facilities are secure and safe from vandalism.
Prevention of Water Pollution	All deliveries should be supervised with bunding provided around all storage areas; spill kits should be readily available; concrete wash-out areas should be carefully positioned to prevent pollution of watercourses, drains or the subsoil/groundwater.
Pollution Response	Appropriate spill kits are to be provided at key locations around the site, this should include all refuelling and storage areas. Emergency spill procedures and contact numbers are to be prominently displayed and communicated to all staff on site.
Dust & Air Pollution	All operations likely to cause excessive dust, such as the cutting of concrete, use of road saws, excavations of loose dry material and vehicle movements during dry weather should be carefully controlled and the use of water sprays, wheel washes and sheeted stockpiles shall be considered. road sweepers to keep roads clean and the maintenance of plant and equipment shall also be adopted to minimise

	emissions of dust and exhaust fumes etc.
Light Pollution	Ensure that any temporary site lighting does not cause a nuisance to the neighbours of the site; give careful consideration of the position of such lighting and where appropriate erect barriers and screens in mitigation.
Noise & Vibration	Ensure any noise reduction measures and barriers are in place and operational. Plant should be well maintained and regularly inspected with the most suitable plant for the job being used, this will help to prevent both noise and vibration issues. Ensure that all plant is turned off when not in use to help reduce and eliminate any unnecessary noise pollution.
Visual Impact	Regular checks should be made to ensure that the site is clean and tidy in appearance. The approach to the site should be clear of obstructions and no employee or contractor vehicles should be allowed to park on the approach roads.
Permits, licences & consents	All permits, consents and necessary licences are in place and valid for the relevant works.
Nature conservation & countryside protection	Consider the impact that any works may potentially have on local flora and fauna.
Heritage & archaeology	Has the local authority archaeological service been informed of any significant historical features or discoveries on or near the site of the works.

ENVIRONMENTAL RISK ASSESSMENT FORM

ENVIRONMENTAL RISK ASSESSMENT

Project Title:		Risk Assess. No.:																					
Task/Activity:		Project No.:																					
		Date Prepared:																					
ENVIRONMENTAL HAZARDS		Potential Impact on:				Likelihood			Severity			Risk Score											
Ref.	Key hazards/Impacts associated with the above task/activity.	Air	Water	Land	Noise & Vibration	Flora & Fauna	Visual	Probable	Occasional	Remote	Major Env. Incident	Serious Env. Incident	Legislative Breach	Minor Incident	Negligible	Likelihood x Severity							
Score:																	3	2	1	5	4	3	2
1																							
2																							
3																							
4																							
5																							
6																							
7																							
Risk Assessment Scores:		10+ Very High Risk				5-9 High Risk				1-4 Low Risk													

PERSONS AFFECTED					
Operatives		Members of Public		Site Visitors	
Other Workers		Managers		Young Persons	
Others					

SPECIALIST EQUIPMENT					
Spill Kits		Fuel Bunds		Respiratory Protection	
Hearing Protection		Water Sprays		Hand/Face Protection	
Acoustic Screens					

ADDITIONAL CONTROL MEASURES	
Information/Instruction/Training	Managerial & Procedural Controls
➤	➤

Physical Controls	Environment Agency Guidance
➤	➤

Comments
➤

ENVIRONMENTAL INCIDENT REPORT FORM

Environmental Incident Report

Project Title:	Project No:
Client:	Site Manager:
Client Contact Details:	Site Manager Contact Details:
Date & time of incident:	Discovered by:
Incident details: (Indicate approx. quantities where applicable)	
Cause of incident:	
Details of any affected watercourse, drain or sewer:	
Details of action taken immediately after incident:	
Details of any further actions needed:	
Incident reported to: EA: Yes / No Local Authority: Yes / No Water Authority: Yes / No Other: Yes / No	Third party contact details:
Additional comments:	

WASTE TRANSFER NOTE

Duty of Care Controlled Waste Transfer Note

DESCRIPTION OF WASTE

1. Description of the waste being transferred:
 2. European Waste Catalogue Code:
 3. How is the waste contained?
Loose Sacks Skip Drum Other → please describe
 4. What is the quantity of waste? (number of drums, tonnes etc.):
-

CURRENT HOLDER OF THE WASTE (TRANSFEROR)

Full name:

Name and address of company:

Which of the following are you? (one or more boxes may apply)

- | | | | | |
|---|--------------------------|--|----------------------------|--------------------------------|
| waste producer | <input type="checkbox"/> | holder of waste management licence | <input type="checkbox"/> → | licence no:
issued by: |
| waste importer | <input type="checkbox"/> | exempt from waste management licensing | <input type="checkbox"/> → | reason why: |
| waste collection authority | <input type="checkbox"/> | registered waste carrier | <input type="checkbox"/> → | registration no:
Issued by: |
| waste disposal authority
(Scotland only) | <input type="checkbox"/> | exempt from requirement to register | <input type="checkbox"/> → | reason why: |
-

PERSON COLLECTING THE WASTE (TRANSFeree)

Full name:

Name and address of company:

Which of the following are you? (one or more boxes may apply)

- | | | | | |
|---|--------------------------|--|----------------------------|--------------------------------|
| waste collection authority | <input type="checkbox"/> | authorised for transport purposes | <input type="checkbox"/> → | specify purpose: |
| waste disposal authority
(Scotland only) | <input type="checkbox"/> | holder of waste management licence | <input type="checkbox"/> → | licence no:
issued by: |
| | | exempt from waste management licensing | <input type="checkbox"/> → | reason why: |
| | | registered waste carrier | <input type="checkbox"/> → | registration no:
issued by: |
| | | exempt from requirement to register | <input type="checkbox"/> → | reason why: |
-

Address of place of transfer:

Date of transfer: Time of transfer (for multiple loads give between dates):

Name and address of broker (if applicable):

Transferor

Transferee

Signature:

Full name:

Representing:

Adapted from HMSO Publication "Waste Management The Duty of Care: A Code of Practice, Annex C.8, March 1996".

EMPLOYEE ENVIRONMENTAL TRAINING RECORD

Employee Environmental Training Record

This document may be used to record any relevant environmental awareness training provided to employees. This document will also assist supervisors in ensuring that all their staff have received the necessary instruction and training to enable them to work safely and without causing unnecessary harm to the environment.

This completed form should be retained in the individual's personnel file.

Employee Name	Employee ID No.
Department	Employee Job Title

Date	Topic	Employees Signature	Trainers Signature

SITE WASTE MANAGEMENT PLAN TEMPLATE

SITE WASTE MANAGEMENT PLAN

Sheet 1 of

Project Title:					Client Name:			
Principal Contractor:					Responsible Person:			
Date Plan Prepared:					Project Cost:			
Project address / location:								
Person and Company Completing this form, if Different:								
Actions Taken Prior to Construction to Reduce Waste:								
Types of waste arising:								
Quantity (in m³)	Re-used onsite	Re-used offsite	Recycled for use on-site	Recycled for use off-site	Sent to recycling facility	Sent to WML exempt site	Disposal to land-fill	WTN completed & Attached?
Inert								
Non- Hazardous								
Hazardous								
Totals (in kg/T)								
Performance Score as %*								
SWMP Target %*								

Declaration

All waste from the site will be dealt with in accordance with the Waste Duty of Care in section 34 of the Environmental Protection Act 1990 and the Environmental Protection (Duty of Care) Regulations 1991; and all materials will be handled efficiently and waste managed appropriately.

Signed:

For Client

.....

For Principal Contractor

NOTES

WTN – Waste Transfer Note

WML – Waste Management License

*There is an option to use this form as a measurement tool to work out savings etc against each waste stream.

Where applicable use additional sheets.

This data sheet must be updated whenever waste is processed or taken away from the site and expanded as necessary.

ENVIRONMENTAL LEGISLATION

The following table lists all relevant environmental legislation that applies to JT Automation Technology Ltd activities, products, and services.

Air Legislation

- Clean Air (Emission of Dark Smoke) (Exemption) Regulations 1969 SI 1263
Clean Air Act 1993
- Climate Change Agreements (Energy-intensive Installations) Regulations 2006 SI 59
- Climate Change Agreements (Eligible Facilities) Regulations 2001, SI 662
- Climate Change Agreements (Eligible Facilities) Regulations 2006 SI 60
- Climate Change Agreements (Eligible Facilities) (Amendment) Regulations 2006 SI 1931
- Climate Change Levy (General) Regulations 2001, SI 838
- Climate Change Levy (Miscellaneous Amendments) Regulations 2005, SI 1716
- Environmental Protection Act 1990
- Pollution Prevention and Control Act 1999
- Crop Residues (Burning) Regulations 1993 SI 1366 (England & Wales)
- Environmental Protection (Controls on Ozone-Depleting Substances) Regulations 2002 SI 528
- Substances that Deplete the Ozone Layer – EU Regulation 2037/2000
- Environmental Protection (Controls on Ozone– Depleting Substances) (Amendment) Regulations 2008 SI 91
- EU Regulation on Certain Fluorinated Greenhouse Gases 842/2006
- EU Regulation on Persistent Organic Pollutants 850/2004
- Fluorinated Greenhouse Gases Regulations 2008 SI 41
- Greenhouse Gas Emissions Trading Scheme Regulations 2005 SI 925
- Greenhouse Gas Emissions Trading Scheme (Amendment) Regulations 2007 SI 465
- Greenhouse Gas Emissions Trading Scheme (Amendment No 2) Regulations 2007 SI 3433
- Non-Road Mobile Machinery (Emission of Gaseous and Particulate Pollutants) (Amendment) Regulations 2004 SI 2034
- Notification of Cooling Towers and Evaporative Condensers Regulations 1992 SI 2225
- Ozone Depleting Substances (Qualifications) Regulations 2006 SI 1510
- Ozone Depleting Substances (Qualifications) (Amendment) Regulations 2008 SI 97
- Solvent Emissions (England and Wales) Regulations 2004 SI 107
- Smoke Control Areas (Exempted Fireplaces) (England) No2 Order 2006 SI 2704
- Volatile Organic Compounds in Paints, Varnishes and Vehicle Refinishing Products Regulations 2005 SI 2773
- Waste Management (Miscellaneous Provisions) (England and Wales) Regulations 2007 SI 1156

Chemicals Legislation

- Batteries and Accumulators (Containing Dangerous Substances) Regulations 1994, SI 232
- Batteries and Accumulators (Containing Dangerous Substances)(Amendment) Regulations 2000, SI 3097
- Carriage of Dangerous Goods and Use of Transportable Pressure Equipment (Amendment) Regulations 2005 SI 1732

- Carriage of Dangerous Goods and Use of Transportable Pressure Equipment Regulations 2007 SI 1573
- Carriage of Dangerous Goods by Rail Regulations 1996 SI 2089
- Carriage of Dangerous Goods by Road Regulations 1996 SI 2095
- Chemicals (Hazard Information and Packaging for Supply) Regulations 2002, SI 1689
- Chemicals (Hazard Information and Packaging for Supply) (Amendment) Regulations 2005 SI 2571
- Control of Asbestos Regulations 2006 SI 2739
- Control Of Major Accident Hazards Regulations 1999, SI 743
- Control of Major Accident Hazards (Amendment) Regulations 2005, SI 1088
- Controls on Certain Azo Dyes and “Blue Colourant” Regulations 2003 SI 3310
- Controls on Dangerous Substances and Preparations Regulations 2006 SI 3311
- Controls on Dangerous Substances and Preparations (Amendment) Regulations 2007 SI 1596
- Controls on Dangerous Substances and Preparations (Amendment)(No 2) Regulations 2007 SI 3438
- Creosote (Prohibition on Use and Marketing)(No2) Regulations 2003 SI 1511
- Creosote (Prohibition on Use and Marketing)(No2)(Amendment) Regulations 2003 SI 2650
- Detergents Regulations 2005, SI 2469
- EU Regulation Concerning the Export and Import of Dangerous Chemicals 304/2003
- EU Regulation on Detergents 648/2004
- Environmental Protection (Disposal of Polychlorinated Biphenyls and other Dangerous Substances) (England and Wales) Regulations 2000, SI 1043
- Environmental Protection (Disposal of Polychlorinated Biphenyls and other Dangerous Substances) (England and Wales) (Amendment) Regulations 2000, SI 3359
- Notification of Installations Handling Hazardous Substances Regulations 1982, SI 1357
- Notification of Installations Handling Hazardous Substances (Amendment) Regulations 2002, SI 2979
- Notification of New Substances Regulations 1993 SI 3050
- Persistent Organic Pollutants Regulations 2007 SI 3106
- Planning (Hazardous Substances) Regulations 1992, SI 656
- Restriction on the Use of Certain Hazardous Substances in Electrical and Electronic Equipment Regulations 2008 SI 37
- Sulphur Content of Liquid Fuels (England and Wales) Regulations 2007 SI 79

Conservation Legislation

- Wildlife and Countryside Act 1981
- Wildlife and Countryside (Amendment) Act 1985
- Wildlife and Countryside (Amendment) Act 1991
- Protection of Badgers Act 1992
- Environment Act 1995
- Countryside and Rights of Way Act 2000
- Natural Environment and Rural Communities Act 2006
- EU Regulation on the Protection of Species of Wild Fauna and Flora by Regulating Trade 338/1997
- Conservation (Natural Habitats etc) Regulations 1994 SI 2716
- Conservation (Natural Habitats &c.) (Amendment) (England) Regulations 2000 SI 192

- Conservation (Natural Habitats, &c.) (Amendment) Regulations 2007 SI 1843
- Wildlife and Countryside Act 1981 (England and Wales) (Amendment)

Energy Legislation

- Buildings Regulations 2000, SI 2531
- Energy Information (Combined Washer-Driers) Regulations 1997 SI 1624
- Energy Information (Dishwashers) Regulations 1999 SI 1676
- Energy Information (Household Electric Ovens) Regulations 2003 SI 751
- Energy Information (Household Refrigerators and Freezers) Regulations 2004 SI 1468
- Energy Information (Lamps) Regulations 1999 SI 1517
- Energy Information (Tumble Driers) Regulations 1996 SI 601
- Energy Information (Washing Machines) Regulations 1996 SI 600
- Energy Information (Washing Machines) (Amendment) Regulations 1997 SI 803
- Energy Information (Household Air Conditioners) (No. 2) Regulations 2005 SI 1726
- Energy Performance of Buildings (Certificates and Inspections) (England and Wales) Regulations 2007 SI 991
- EU Regulation on a Revised Community Eco-Label Award Scheme 1980/2000

Land Legislation

- Agricultural Land (Removal of Surface Soil) Act 1953
- Countryside and Rights of Way Act 2000
- Environmental Protection Act 1990
- Environment Act 1995
- Wildlife and Countryside Act 1981
- Wildlife and Countryside Act 1981 (England and Wales) (Amendment) Regulations 2004 SI 1487
- Natural Environment and Rural Communities Act 2006
- Wildlife and Countryside (Amendment) Act 1985
- Wildlife and Countryside (Amendment) Act 1991
- Action Programme for Nitrate Vulnerable Zones (England and Wales) Regulations 1998 SI 1202
- Animal By-Products Regulations 2005 SI 2347
- Contaminated Land (England) Regulations 2006 SI 1380
- Control of Pollution (Silage, Slurry and Agricultural Fuel Oil) Regulations 1991 SI 324
- Control of Pollution (Silage, Slurry and Agricultural Fuel Oil) (Amendment) Regulations 1996 SI 2044
- Control of Pollution (Silage, Slurry and Agricultural Fuel Oil) (Amendment) Regulations 1997 SI 547
- Environmental Impact Assessment (Forestry) (England and Wales) Regulations 1999, SI 2228
- Environmental Impact Assessment (Forestry) (England and Wales) (Amendment) Regulations 2006 SI 3106
- Environmental Impact Assessment (Uncultivated Land and Semi-natural Areas) (England) Regulations 2001, SI 3966
- Environmental Impact Assessment (Uncultivated Land and Semi-natural Areas) (England)(Amendment) Regulations 2005, SI 1430
- Farm Waste Grant (Nitrate Vulnerable Zones) (England) Scheme 2003 SI 562
- Nitrate Vulnerable Zones (Additional Designations) (England) (No2) Regulations 2002, SI 2614

- Radioactive Contaminated Land (Enabling Powers) (England) Regulations 2005, SI 3467
- Radioactive Contaminated Land (Modification of Enactments) (England) Regulations 2006 SI 1379
- Radioactive Contaminated Land (Modification of Enactments)(England)(Amendment) Regulations 2007 SI 3245
- Sludge (Use in Agriculture) Regulations 1989 SI 1263
- Sludge (Use in Agriculture) (Amendment) Regulations 1990, SI 880

Noise and Statutory Nuisance Legislation

- Anti-social Behaviour Act 2003
- Civil Aviation Act 1982
- Control of Pollution Act 1974
- Clean Neighbourhoods and Environment Act 2005
- Environmental Protection Act 1990
- Local Government (Miscellaneous Provisions) Act 1982
- Control of Noise (Codes of Practice for Construction and Open Sites) (England) Order 2002, SI 461
- Environmental Noise (England) Regulations 2006 SI 2238
- Household Appliances (Noise Emission) Regulations 1990 SI 161
- Household Appliances (Noise Emission) (Amendment) Regulations 1994 SI 1386
- Noise Emission in the Environment by Equipment for Use Outdoors Regulations 2001 SI 1701
- Noise Emission in the Environment by Equipment for Use Outdoors (Amendment) Regulations 2001, SI 3958
- Noise Emission in the Environment by Equipment for Use Outdoors (Amendment) Regulations 2005, SI 3525
- Statutory Nuisance (Appeals) Regulations 1995 SI 2644
Link to OPSI website - Statutory Nuisance (Appeals) Regulations 1995 SI 2644
- Statutory Nuisances (Artificial Lighting)(Designation of Relevant Sports)(England) Order 2006 SI 781
- Statutory Nuisance (Appeals)(Amendment)(England) Regulations

Pesticides and Biocides Legislation

- Food and Environment Protection Act 1985
- Pesticides Act 1998
- Plant Health Act 1967
Biocidal Products Regulations 2001 SI 880
- Biocidal Products (Amendment) Regulations 2003 SI 429
- Biocidal Products (Amendment) Regulations 2005 SI 2451
- Biocidal Products (Amendment) Regulations 2007 SI 293
- Control of Pesticides Regulations 1986 SI 1510 (not available online)
- Control of Pesticides (Amendment) Regulations 1997 SI 188
- Plant Health (England) Order 2005 SI 2530
- Plant Protection Products (Basic Conditions) Regulations 1997 SI 189
- Plant Protection Products (Amendment) Regulations 2005 SI 3197
- Plant Protection Products (Amendment) (No 2) Regulations 2006 SI 2933
- Plant Protection Products Regulations 2005 SI 1435
- Plant Protection Products (Amendment) Regulations 2006 SI 1295
- Plant Protection Products (Amendment) Regulations 2007 SI 636

Environmental Permitting Legislation

- Note – From 6 April 2008 PPC and IPC legislation has been replaced (for England and Wales) by Environmental Permitting Legislation
- Pollution Prevention and Control Act 1999
- Environmental Permitting (England and Wales) Regulations 2007 SI 3538

Radioactive Substances Legislation

- High-activity Sealed Radioactive Sources and Orphan Sources Regulations 2005, SI 2686
- Radioactive Material (Road Transport) Act 1991
- Radioactive Substances Act 1993
- Radioactive Material (Road Transport) Regulations 2002, SI 1093
- Radioactive Material (Road Transport) (Amendment) Regulations 2003, SI 1867
- Radioactive Substances (Appeals) Regulations 1990, SI 2504

Waste Legislation

- Control of Pollution (Amendment) Act 1989
- Clean Neighbourhoods and Environment Act 2005
- Environment Act 1995
- Environmental Protection Act 1990
- Controlled Waste Regulations 1992 SI 588
- Controlled Waste (Amendment) Regulations 1993 SI 566
- Controlled Waste (Registration of Carriers and Seizure of Vehicles) Regulations 1991 SI 1624
- Controlled Waste (Registration of Carriers and Seizure of Vehicles) (Amendment) Regulations 1998 SI 605
- End of Life Vehicles Regulations 2003, SI 2635
- End-of-Life Vehicles (Producer Responsibility) Regulations 2005 SI 263
- Environmental Permitting (England and Wales) Regulations 2007 SI 3538
- Environmental Protection (Duty of Care) Regulations 1991 SI 2839
- Environmental Protection (Duty of Care) (England) (Amendment) Regulations 2003 SI 63
- EU Regulation on the Supervision and Control of Shipments of Waste 259/1993
- EU Regulation laying down Health Rules concerning Animal By-Products not intended for Human Consumption 1774/2002
- EU Regulation on Shipments of Waste (1013/2006)
- Hazardous Waste (England and Wales) Regulations 2005, SI 894
- List of Wastes (England) (Amendment) Regulations 2005 SI 1673
- List of Wastes (England) Regulations 2005 SI 895
- Packaging (Essential Requirements) Regulations 2003 SI 1941
- Packaging (Essential Requirements) (Amendment) Regulations 2004 SI 1188
- Packaging (Essential Requirements) (Amendment) Regulations 2006 SI 1492
- Producer Responsibility Obligations (Packaging Waste) Regulations 2007 SI 871
- Producer Responsibility Obligations (Packaging Waste) (Amendment) Regulations 2008 SI 413
- Site Waste Management Plans Regulations 2008 SI 314
- Transfrontier Shipment of Radioactive Waste Regulations 1993, SI 3031
- Transfrontier Shipment of Waste Regulations 2007 SI 1711

- Transfrontier Shipment of Waste (Amendment) Regulations 2008 SI 9
- Waste Electrical and Electronic Equipment Regulations 2006 SI 3289
- Waste Electrical and Electronic Equipment (Amendment) Regulations 2007 SI 3454
- Waste Incineration (England and Wales) Regulations 2002, SI 2980
- Waste Management (England and Wales) Regulations 2006 SI 937
- Waste Management Licensing Regulations 1994 SI 1056
- Waste Management (Miscellaneous Provisions) (England and Wales) Regulations 2007 SI 1156

Water Legislation

- Water Act 2003
- Water Industry Act 1991
- Water Industry Act 1999
- Water Resources Act 1991
- Anti-Pollution Works Regulations 1999 SI 1006
- Control of Pollution (Applications, Appeals and Registers) Regulations 1996, SI 2971
- Control of Pollution (Oil Storage) (England) Regulations 2001 SI 2954
- Groundwater Regulations 1998 SI 2746
- Protection of Water Against Agricultural Nitrate Pollution (England and Wales) Regulations 1996 SI 888
- Protection of Water Against Agricultural Nitrate Pollution (England and Wales) (Amendment) Regulations 2006, SI 1289
- Water Resources (Abstraction and Impounding) Regulations 2006 SI 641
- Water Resources (Environmental Impact Assessment) (England and Wales) Regulations 2003 SI 164
- Water Resources (Environmental Impact Assessment)(England and Wales)(Amendment) Regulations 2006 SI 3124
- Water Supply (Water Quality) Regulations 2000, SI 3184
- Water Supply (Water Quality) Regulations 2001, SI 3911
- Water Supply (Water Quality) (Amendment) Regulations 2001, SI 2885

GLOSSARY OF KEY ENVIRONMENTAL TERMS

BAT: Best Available Techniques, defined under Integrated Pollution Prevention and Control (IPPC). Note that BAT has many more cost and implementation issues than its predecessor BATNEEC.

BATNEEC: Best Available Techniques Not Entailing Excessive Cost, defined under Integrated Pollution Control (IPC).

Biodiversity: The range of plant and animal species and communities associated with terrestrial, aquatic and marine habitats.

Biological treatment: Any biological process that changes the properties of waste (for example, anaerobic digestion, composting). Biological treatment includes land spreading activities that are licensed.

BPEO: Best Practicable Environmental Option, a procedure that takes into account the total impact of a process and the technical possibilities for dealing with it. BPEO establishes the waste management option, or mix of options, that provides the most benefits or the least damage to the environment as a whole, at acceptable cost, in the long-term as well as in the short-term.

Climate Change Levy: A tax introduced on 1 April 2001, which is designed to stimulate business improvements in energy efficiency.

Controlled waste: The UK term for wastes controlled under the Waste Framework Directive: any household, industrial or commercial waste.

DEFRA: Department for Environment, Food and Rural Affairs

Eco-efficiency: The delivery of competitively priced goods and services that satisfy human needs and bring quality of life, while progressively reducing environmental impacts and resource intensity throughout the life cycle, to a level at least in line with the earth's estimated carrying capacity.

ELV(s): End of Life Vehicle – scrap cars and other vehicles. The subject of an EU Directive.

EMAS: (European) Eco-management and Audit Scheme. A European voluntary scheme for industrial sites. To register under EMAS your company should have a clearly defined strategy for environmental management, complete with quantified objectives.

EMS: Environmental Management Systems: the part of an overall management system that includes organisational structure, planning activities, responsibilities, practices, procedures, processes and procedures for developing, implementing, achieving, reviewing and maintaining the environmental policy (see *ISO 14001*).

Energy recovery: The recovery of useful energy in the form of heat and/or power from burning waste. Generally applied to incineration, but can also include the combustion of landfill gas and gas produced during anaerobic digestion.

Environment Agency: The principal environmental regulator in England and Wales. Established in April 1996 to combine the functions of former waste regulation authorities, the National Rivers Authority and Her Majesty's Inspectorate of Pollution. Intended to promote improved waste management and consistency in waste regulation across England and Wales.

Environmental accounting: Any quantitative approach to linking financial and environmental performance.

Environmental footprint: The impact of an organisation in environmental terms (resource use, waste generation, physical environmental changes etc).

Environmental Technology Best Practice Programme (ETBPP): A Government (DEFRA) initiative to demonstrate the benefits of reducing resource use and environmental impact to companies across the whole of the UK.

EU Directive: A European Union (formerly EC-European Community) legal instruction, binding on all Member States but which must be implemented through national legislation within a prescribed time-scale.

Exempt facility: A waste recovery operation (also occasionally certain disposal at the waste producer and some storage activities) registered with, but not licensed by, the Environment Agency. Exempt facilities are subject to general rules (e.g. on the types and quantities of wastes received).

Hazardous waste: Defined by EU legislation as the most harmful wastes to people and the environment. Hazardous wastes are listed in the 'List of Wastes (England) Regulations 2005.

Fauna: The collective term for animal life.

Flora: The collective term for plant life.

Incineration: The burning of waste at high temperatures in the presence of sufficient air to achieve complete combustion, either to reduce its volume (in the case of municipal solid waste) or its toxicity (for example, for organic solvents). Municipal solid waste incinerators recover heat and/or power. The main emissions are carbon dioxide, water and ash residues.

Industrial waste: Waste from any factory or industrial process (excluding mines and quarries).

Inert waste: Chemically inert, non-combustible, non-biodegradable and non-polluting waste defined in the EU Directive on the Landfill of Waste.

IPC: Integrated Pollution Control, a system introduced under the Environmental Protection Act 1990, which controls polluting substances from industrial processes to the three environmental media of air, land and water. IPC was designed to ensure that best available techniques not entailing excessive costs are used to prevent, or where that is not practicable, to reduce, emissions from a range of the potentially most polluting industrial processes, including some waste management facilities. Gradually being replaced with Pollution, Prevention and Control requirements under the EU IPPC Directive.

IPPC: Integrated Pollution Prevention and Control, an EC Directive implemented in the UK by the Pollution Prevention and Control (England and Wales) Regulations 2000. This is similar to IPC but also covers noise, vibration, resource minimisation, energy efficiency, environmental accidents and site protection and covers more industrial processes.

ISO 14001: An environmental management system (EMS) is a systematic approach to dealing with the environmental impacts of an organisation. It is a framework that enables an organisation of any size or type to control the impact of its activities, products or services on the natural environment. ISO 14001 Environmental management systems is an international standard that specifies the requirements.

Landfill (sites): Licensed facilities where waste is permanently deposited for disposal.

Landfill tax: A tax that applies to active and inert waste, disposed at a licensed landfill. The aim of the tax is to send a tough signal to waste managers to switch to less environmentally damaging alternatives to disposal.

Land spreading: Recovering waste by spreading onto land principally for agricultural benefit or ecological improvement. Sewage sludge and wastes from, for example, the food, brewing and paper pulp industries can be used for this purpose.

LFD: Landfill Directive

Licensed site/Waste management facility: A waste disposal or recovery facility licensed under the Environmental Protection Act.

Life Cycle Analysis (Assessment): LCA is a systematic technique for identifying and evaluating the potential environmental benefits and impacts (use of resources; human health; ecological consequences) associated with a product or function throughout its entire life from extraction of raw materials to its eventual disposal and assimilation into the environment. LCA helps to place the assessment of the environmental costs and benefits of these various options, and the development of appropriate and practical waste management policies, on a sound and objective basis.

Pollution incidents:

- Category 1: incidents having persistent and extensive impact on land, air or water.
- Category 2: incidents having significant impact on land, air or water.
- Category 3: incidents having minimal impact on land, air or water.

Process Mapping: A logical step by step representation of business activities showing key inputs/outputs.

Producer responsibility: Requires industry and commerce involved in the manufacture, distribution and sale of particular goods to take greater responsibility for the disposal and/or recovery of those goods at the end of their useful life.

Recovery: Involves the recovery of value from waste, through recycling, composting or incineration with energy recovery.

Recycling: Involves the reprocessing of wastes, either into the same material (closed-loop) or a different material (open-loop recycling). Commonly applied to non-hazardous wastes such as paper, glass, cardboard, plastics and metals. However, hazardous wastes (such as solvents) can also be recycled by specialist companies, or using in-house equipment.

Reduction: Reducing the quantity or the hazard of a waste produced from a process. It usually results in reduced raw material and energy demands – thus also reducing costs.

Re-use: Using materials or products again, for the same or a different purpose, without material reprocessing (such as glass milk bottles or returnable plastic crates).

Sustainable development: Development which meets the needs of the present without compromising the ability of future generations to meet their own needs.

Sustainable waste management: Using material resources efficiently to cut down on the amount of waste produced. And, where waste is generated, dealing with it in a way that actively contributes to the economic, social and environmental goals of sustainable development.

TCOW: True Cost of Waste. The cost of waste is always much greater than just the cost of disposal, and can be as much as 5-10% of a company's turnover. Waste disposal is the obvious 'visible' cost but there are numerous hidden costs.

Treatment: Involves the physical, chemical or biological processing of waste to reduce their volume or harmfulness.

Waste hierarchy: The ranking of waste management options in order of sustainability.

Waste management: Management of the collection, recovery and disposal of wastes, including options for waste reduction.

Waste minimisation: The reduction of waste at source, by understanding and changing processes to reduce and prevent waste. This is also known as process or resource efficiency. Waste minimisation can include the substitution of less environmentally harmful materials in the production process.